

Python-Drive



*The ideal flexible drive unit
from 10 up to 1000 HP*

CV drive shaft systems from Python-Drive

Python-Drive

Python-Drive the ideal vibration-free drive unit

from 10 HP up to 1000 HP

Python-Drive features:

- Double ended constant velocity drive shaft suitable for both Pleasure and High Performance applications.
- Eliminates the need for exact alignment of prop shaft to gearbox.
- Maintenance free thrust bearings.

Advantages of fitting a Python-Drive:

- The constant velocity drive shaft guarantees a constant prop shaft speed, even when angles are unequal.
- Propulsion thrust is isolated from the gearbox by being absorbed by the rubber mounting blocks.
- Not only is the Python-Drive robustly constructed, it is available in both Imperial and Metric dimensions, covering prop shafts from 3/4" (19.05 mm.) up to 4" (100 mm.).
- The thrust bearing units can be used as stand alone units, on request they can be machined to suit universal (cardan) shafts.
- Python-Drive constant velocity drive shafts are able to take torques of up to 1,500 kgm. (appr. 14.7 kNm.).
- Drive Shafts are available in different lengths and can be made to suit individual sizes.
- Supplied complete with all necessary studs, bolts, washers, gearbox flange and accompanied by an easily understood installation manual.



Look at www.PythonDrive.com for our online calculation program, or use one of the following formulas to calculate the ideal Python-Drive unit for your installation:

$$\left(\frac{\text{Max. rating of the engine in kW}}{\text{Max. RPM. of the engine (n)}} \right) \times 9680 \times \text{Ratio of the gearbox} = \text{Shaft torque (A in Nm)}$$

$$\text{Or: } \left(\frac{\text{HP}}{\text{n}} \right) \times 726 \times \text{Ratio of the gearbox} = \text{Shaft torque (A in kgm)}$$

Example: (135 HP : 2500 rpm.) X 726 X 2 (Ratio gearbox) = 78,4 kgm (prop shaft torque)

Furthermore the maximum propeller thrust should not exceed the published rating.

Units : 1 kgm = 9,807 Nm, 1 HP = 0,736 kW, 1 kg = 9,807 N, 1 kN = 1.000 N, 1 lbf = 4.448 N, 1 lbft = 0.1383 kgm.

Python-Drive

Type	P30-R
Maximum shaft torque	30 kgm
	294 Nm
Propeller shaft diam.	19 - 30 mm
Maximum prop. thrust	4.3 kN
Example use with diesel engine	50 HP / 3000 rpm 2.5:1 gearbox
CV drive shaft optional lengths	145, 165 or 195mm

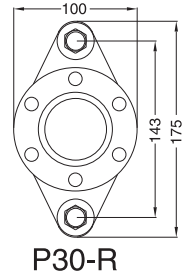
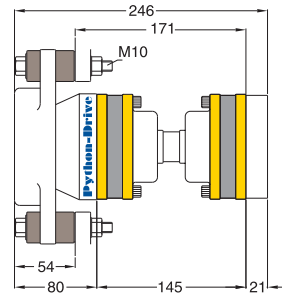

P30-R

Type	P60-B
Maximum shaft torque	60 kgm
	588 Nm
Propeller shaft diam.	1.25" - 40 mm
Maximum prop. thrust	5.7 kN
Example use with diesel engine	70 HP / 2600 rpm 3:1 gearbox
CV drive shaft optional lengths	145, 165 or 195mm

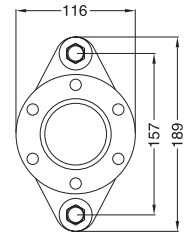
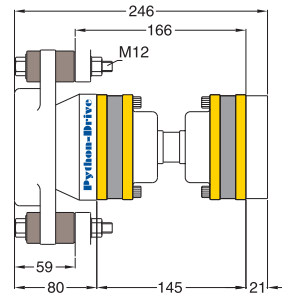

P60-B

Type	P60-K
Maximum shaft torque	60 kgm
	588 Nm
Propeller shaft diam.	30 - 40 mm
Maximum prop. thrust	5.7 kN
Example use with diesel engine	70 HP / 2600 rpm 3:1 gearbox
CV drive shaft optional lengths	145, 165 or 195mm

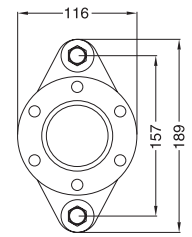
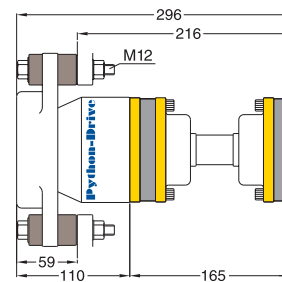

P60-K

Type	P80-M
Maximum shaft torque	80 kgm
	785 Nm
Propeller shaft diam.	30 - 45 mm
Maximum prop. thrust	8 kN
Example use with diesel engine	105 HP / 3000 rpm 3:1 gearbox
CV drive shaft optional lengths	145, 165 or 195mm

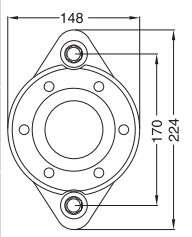
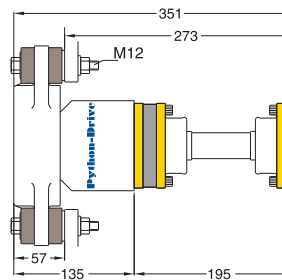

P80-M

Type	P80-S
Maximum shaft torque	80 kgm
	785 Nm
Propeller shaft diam.	30 - 45 mm
Maximum prop. thrust	12 kN
Example use with diesel engine	130 HP / 2400 rpm 2:1 gearbox
CV drive shaft optional lengths	145, 165 or 195mm

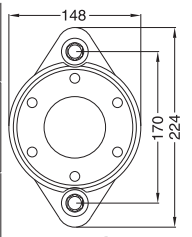
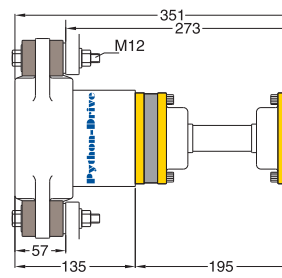

P80-S

Python-Drive

Type	<i>P110-S</i>
Maximum shaft torque	110 kgm
	1.080 Nm
Propeller shaft diam.	35 - 45 mm
Maximum prop. thrust	12 kN
Example use with diesel engine	135 HP / 2700 rpm 3:1 gearbox
CV drive shaft optional lengths	180 or 225 mm

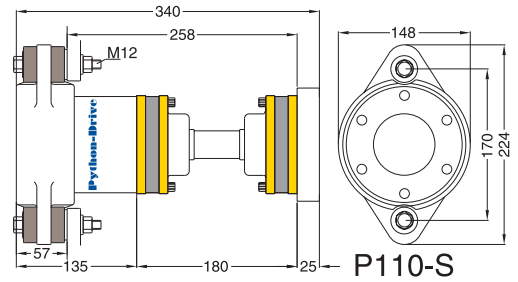

Type	<i>P110-T</i>
Maximum shaft torque	110 kgm
	1.080 Nm
Propeller shaft diam.	35 - 50 mm (2")
Maximum prop. thrust	18 kN
Example use with diesel engine	180 HP / 2400 rpm 2:1 gearbox
CV drive shaft optional lengths	180 or 225 mm

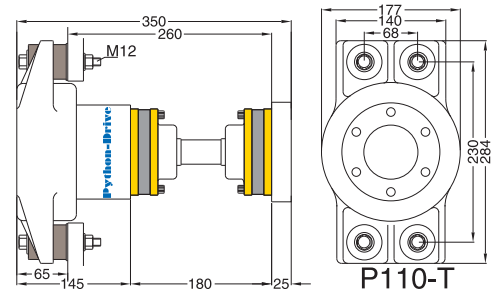

Type	<i>P140-T</i>
Maximum shaft torque	140 kgm
	1.370 Nm
Propeller shaft diam.	40 - 55 mm
Maximum prop. thrust	18 kN
Example use with diesel engine	190 HP / 2500 rpm 2.5:1 gearbox
CV drive shaft optional lengths	180 or 225 mm

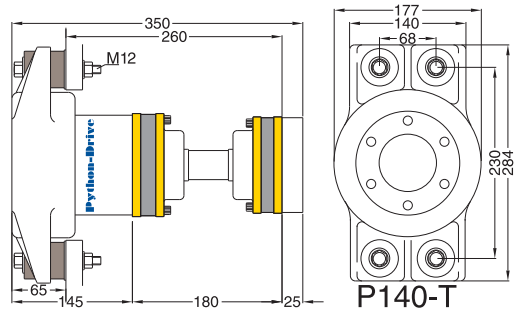

Type	<i>P200-T</i>
Maximum shaft torque	200 kgm
	1.960 Nm
Propeller shaft diam.	40 - 60 mm
Maximum prop. thrust	18 kN
Example use with diesel engine	240 HP / 2300 rpm 2.5:1 gearbox

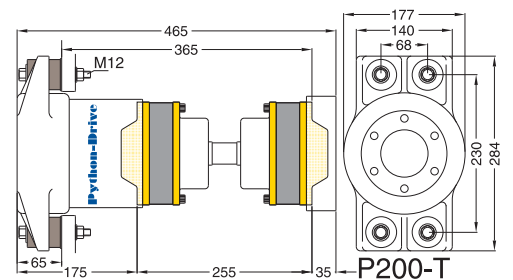

Type	<i>P200-Q</i>
Maximum shaft torque	200 kgm
	1.960 Nm
Propeller shaft diam.	45 - 60 mm
Maximum prop. thrust	22 kN
Example use with diesel engine	250 HP / 2800 rpm 3:1 gearbox
Recommended rpm PD-Q thrust unit	Max. 1500 rpm

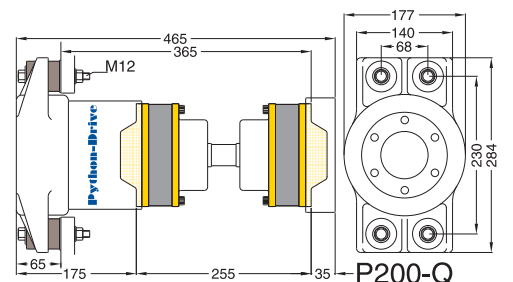

Python-Drive

Type	<i>P200-W</i>
Maximum shaft torque	200 kgm
	1.960 Nm
Propeller shaft diam.	50 - 60 mm
Maximum prop. thrust	30 kN
Example use with diesel engine	275 HP / 2500 rpm 2.5:1 gearbox

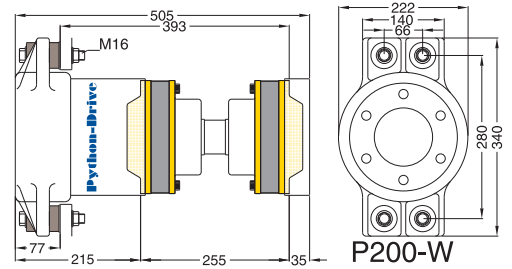

Type	<i>P501-Q</i>
Maximum shaft torque	500 kgm
	4.900 Nm
Propeller shaft diam.	50 - 60 mm
Maximum prop. thrust	22 kN
Example use with diesel engine	300 HP / 2000 rpm 3:1 gearbox
Recommended rpm PD-Q thrust unit	Max. 1500 rpm
CV drive shaft optional lengths 221 or 260 mm	

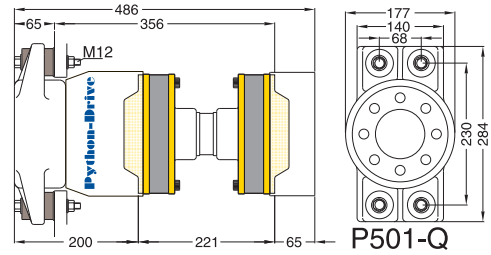

Type	<i>P501-W</i>
Maximum shaft torque	500 kgm
	4.900 Nm
Propeller shaft diam.	50 - 80 mm
Maximum prop. thrust	30 kN
Example use with diesel engine	400 HP / 2200 rpm 3:1 gearbox
CV drive shaft optional lengths 221 or 260 mm	

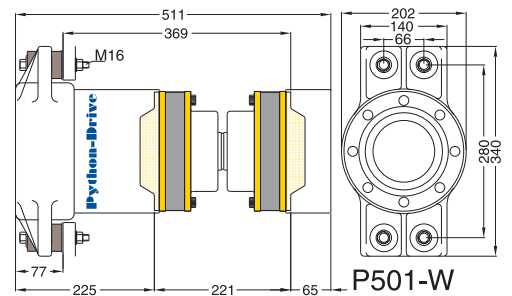

Type	<i>P501-L</i>
Maximum shaft torque	500 kgm
	4.900 Nm
Propeller shaft diam.	50 - 80 mm
Maximum prop. thrust	45 kN
Example use with diesel engine	500 HP / 2200 rpm 3:1 gearbox
Recommended rpm PD-L thrust unit	Max. 1500 rpm
CV drive shaft optional lengths 221 or 260 mm	

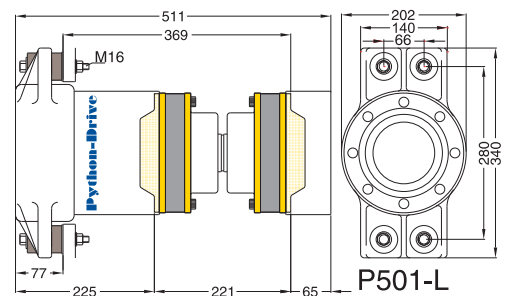

Type	<i>P1000-L</i>
Maximum shaft torque	1000 kgm
	9.810 Nm
Propeller shaft diam.	70 - 80 mm
Maximum prop. thrust	45 kN
Example use with diesel engine	750 HP / 2000 rpm 3:1 gearbox
Recommended rpm PD-L thrust unit	Max. 1500 rpm

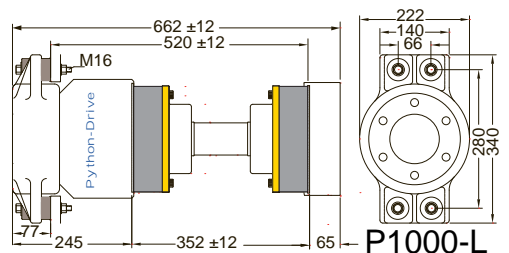

Python-Drive

Type	<i>P1000-G</i>
Maximum shaft torque	1000 kgm
	9.810 Nm
Propeller shaft diam.	70 - 100 mm
Maximum prop. thrust	60 kN
Example use with diesel engine	800 HP / 1900 rpm 3:1 gearbox
Recommended rpm PD-G thrust unit	Max. 1500 rpm

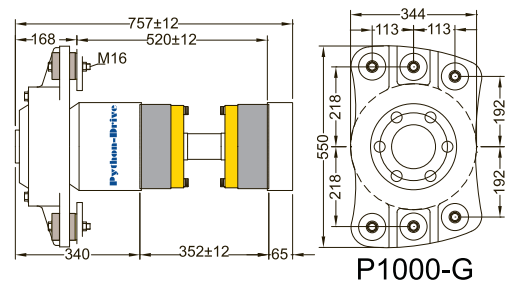

P1000-G

Type	<i>P1500-G</i>
Maximum shaft torque	1500 kgm
	14.715 Nm
Propeller shaft diam.	80 - 100 mm
Maximum prop. thrust	60 kN
Example use with diesel engine	950 HP / 1900 rpm 3:1 gearbox
Recommended rpm PD-G thrust unit	Max. 1500 rpm

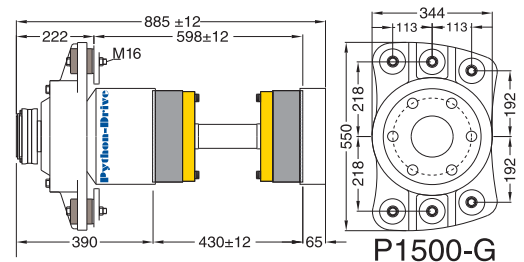

P1500-G

- A. Bearing housing
- B. Thrust bearing
- C. Thrust rubbers
- D. Hub
- E. Internal clamp
- F. CV joint thrust bearing side
- G. Intermediate shaft
- H. Boot kit
- I. CV joint gearbox side
- J. Gearbox adaptor flange
- K. Propeller shaft

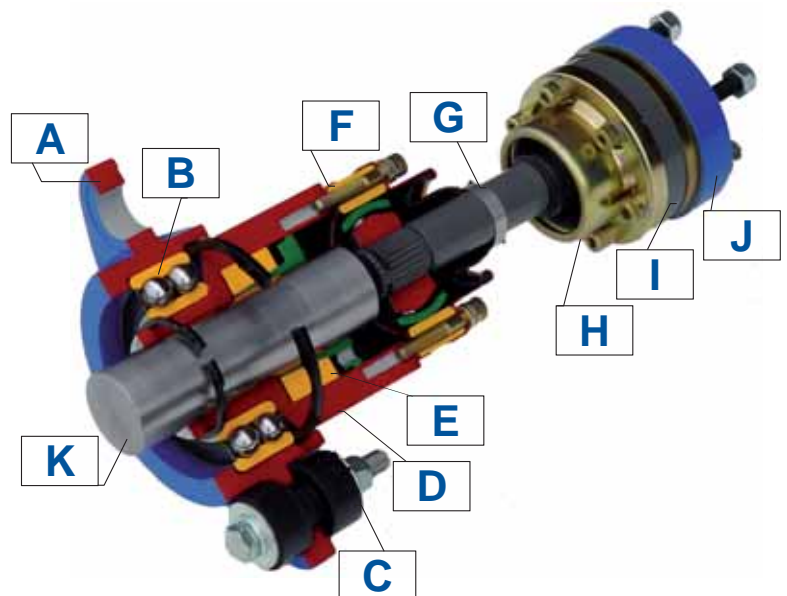

Above mentioned Python-Drive units are supplied complete with CV-drive shaft, thrust bearing unit, adaptor flanges for most regular 4", 5", 5.75" and 7.25" gearbox flanges, all bolts, nuts, thrust-rubbers and lock washers. Also included is an easy to read installation manual.

Python-Drive maintenance free thrust bearing-units

The **Python-Drive** unit can be easily assembled over the propeller shaft and mounted exactly where required, between the stern tube and the gearbox. Combination with a (double) flexible shaft coupling or alike to be mounted on the end of the shaft is thus throughout possible. The propeller thrust is transmitted to the ships hull by means of rubber silent blocks. The unit comes complete with internal clamp coupling, bolts, nuts and rubber silent blocks.

Below are some examples of stand alone thrust bearing units:



Below a PD-G thrust bearing unit, shaft diam. up to 100 mm., max. propeller thrust up to 60 kN.

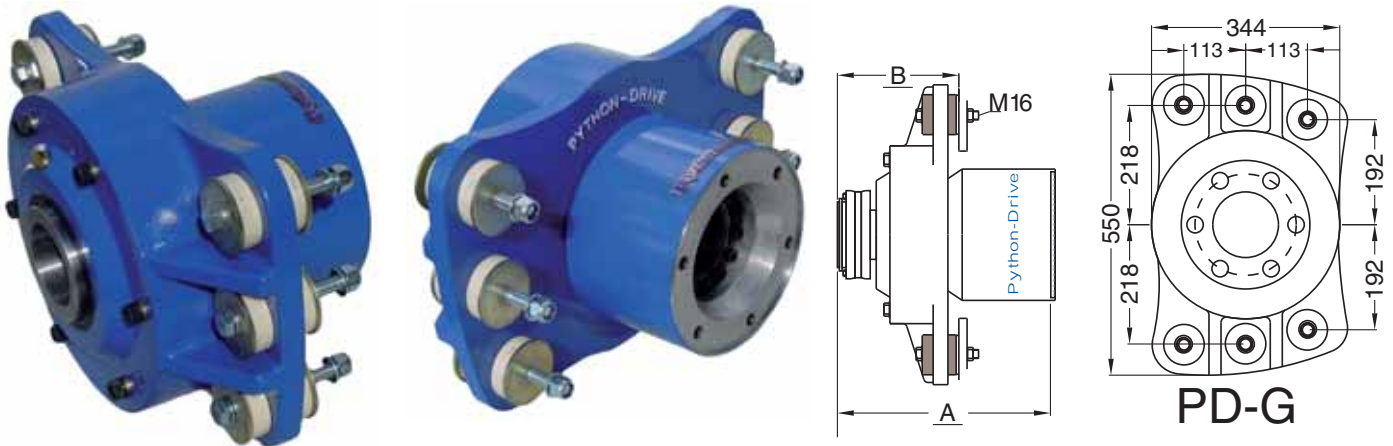

Individual Python-Drive CV drive shafts

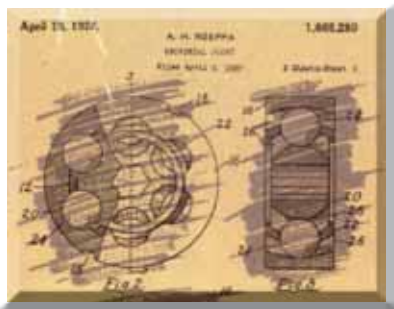

Picture left: Drawing of the original design of the first CV joint (constant velocity joint) by Alfred Rzeppa from 1927. On basis of this drawing the CV joint was patented.

Python-Drive CV drive shafts operate in the same way; they have no torsional or inertial excitations inherent in cardan style drive shafts. The smooth torque transmitted from a **Python-Drive** CV drive shaft occurs even when the operating angles are unequal. The **Python-Drive** CV drive shaft will successfully accommodate unequal angles better than any other coupling device.

Python-Drive constant velocity drive shafts may be used to a maximum angle of 8° (8° per CV-side). The maximum prop shaft rpm. may be 4500 rpm. (depending on model). For more detailed information, please refer to the installation manual. **Python-Drive** CV-drive shafts are also available in custom lengths.



Python-MEGAFLEX

Ultra flexible CV drive shaft combinations

The **Python-MEGAFLEX** consists of a standard **Python-Drive** system and features an incorporated Vulkan Megiflex flexible shaft coupling with integrated bearings. Complete units for prop shaft installations from 60 - 2,800 Nm are available.

Features:

- More silent than any comparable gearbox to prop shaft coupling.
- Smoother engagement of gearbox.
- Absorption of driveline vibrations by the Vulkan Megiflex coupling.
- Preventing high frequency vibrations from causing wear or damage to the prop shaft installation.
- Allows for even softer flexible engine mounts.
- Length compensation by the CV drive shaft, so no thrust loads on the Megiflex coupling.
- Ease of installation; the unit comes in three main components: thrust block, CV drive shaft and fully assembled Vulkan Megiflex unit with premounted gearbox adaptor flange.
- Saving installation time; because the system contains a drive shaft with two CV joints (unlike other systems), it 'hinges' on these two CV joints, which makes installing the unit a piece of cake!
- All installation materials like bolts, nuts, washers and gearbox adaptor flange included.
- No maintenance required.
- Available in any Python-Drive combination up to 2,800 Nm torque, even with larger length CV drive shafts.

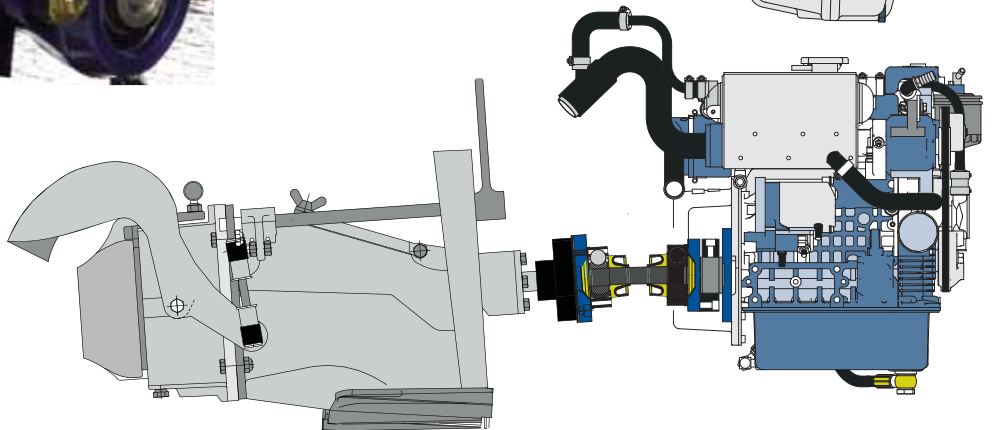
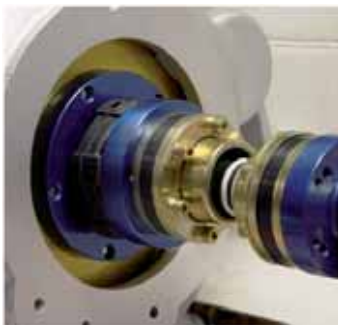
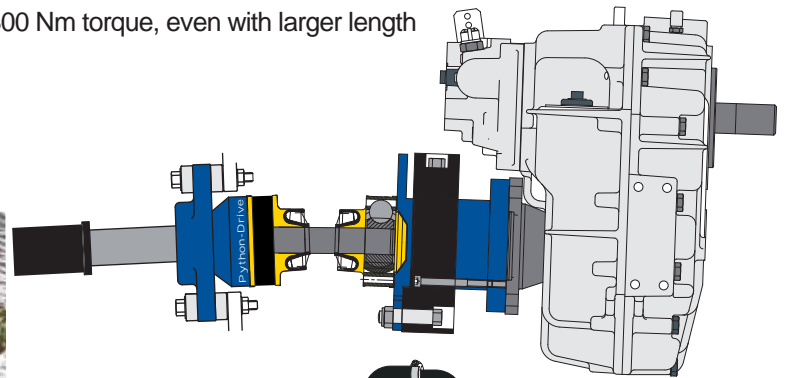

For more detailed information about the **Python-MEGAFLEX**, please contact your **Python-Drive** dealer.

All the above data and limits are for pleasure craft applications only. For commercial applications we'll gladly calculate the correct **Python-Drive** combination for you. Please always refer to the installation manual prior to fitment.

Your **Python-Drive** dealer:

Look at www.pythondrive.com for our online calculation program, international distributors, installation manual, other languages and additional information.

Manufacturer: Dintra Transmissies Vof - Keizerswoert 30 - 3881 LE Putten - NL Tel. 0031 - 341 353712 Fax 0031 341 360046
Website: www.pythondrive.com E-mail: info@pythondrive.com

The information given in this leaflet is correct at the time of printing. However in the interest of technical progress, design specifications are subject to change without notice.

2011 (c)